

Helium Aerostat Design

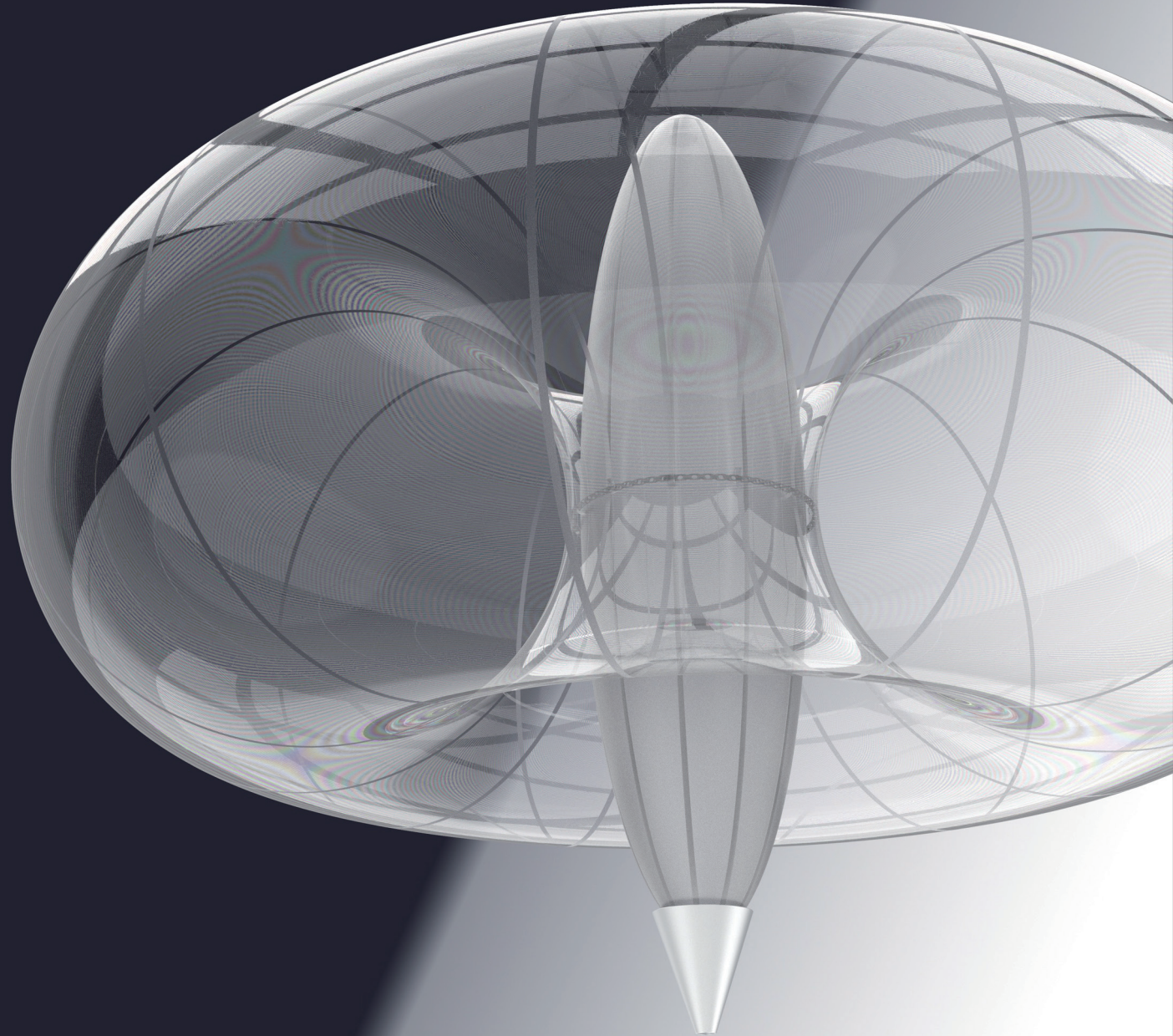

Technical principle - main and auxiliary airbag structure

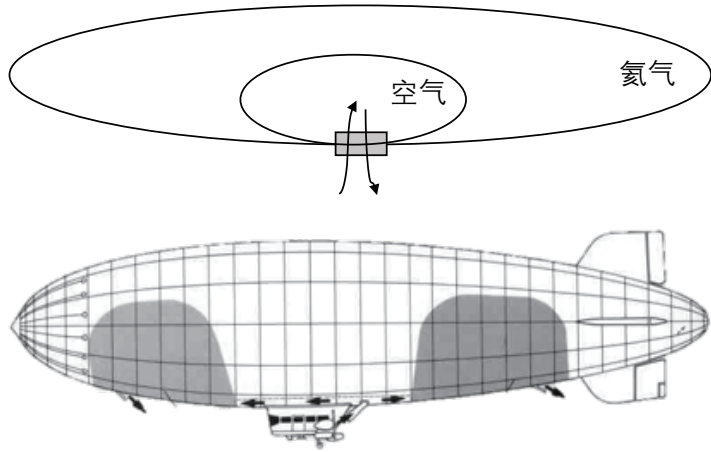

Principle description:

The primary and secondary airbags are a method of altitude control for airships and high-altitude balloons. The main airbag is filled with helium, the secondary airbag is filled with air, and the air is pumped into the air bag. The aerostat becomes heavier and sinks. The air sac is vented, the aerostat lightens and floats.

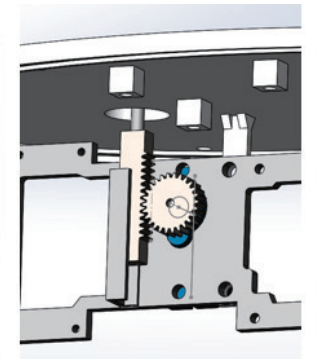
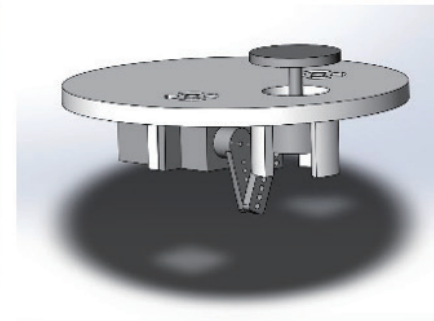
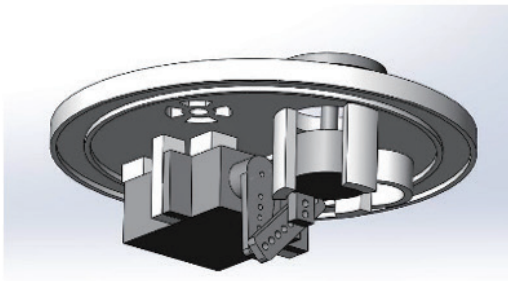
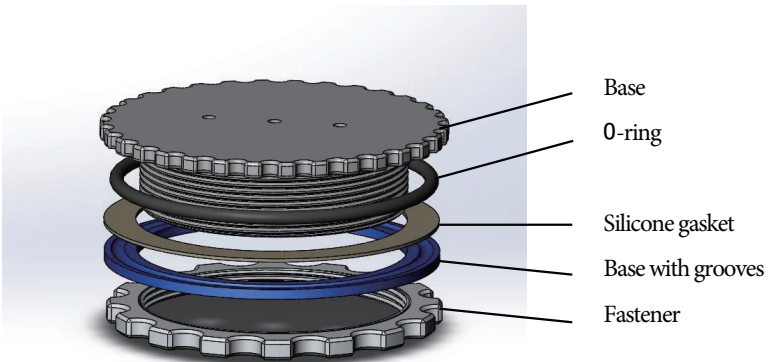
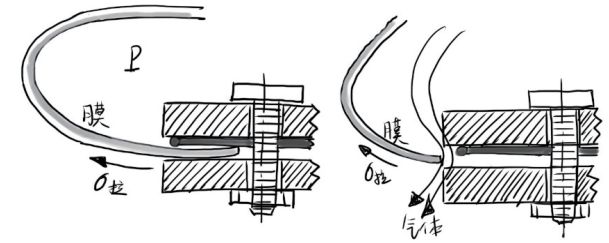
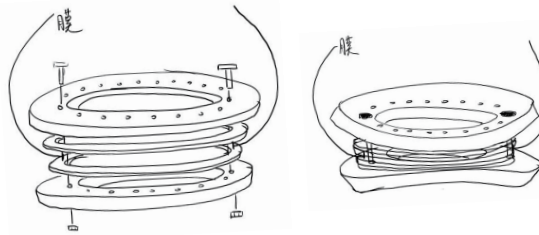
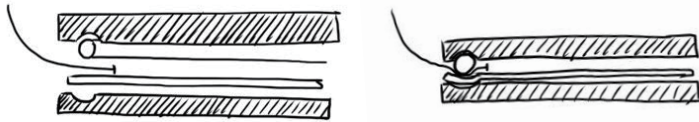

Technical principle - electronic control system

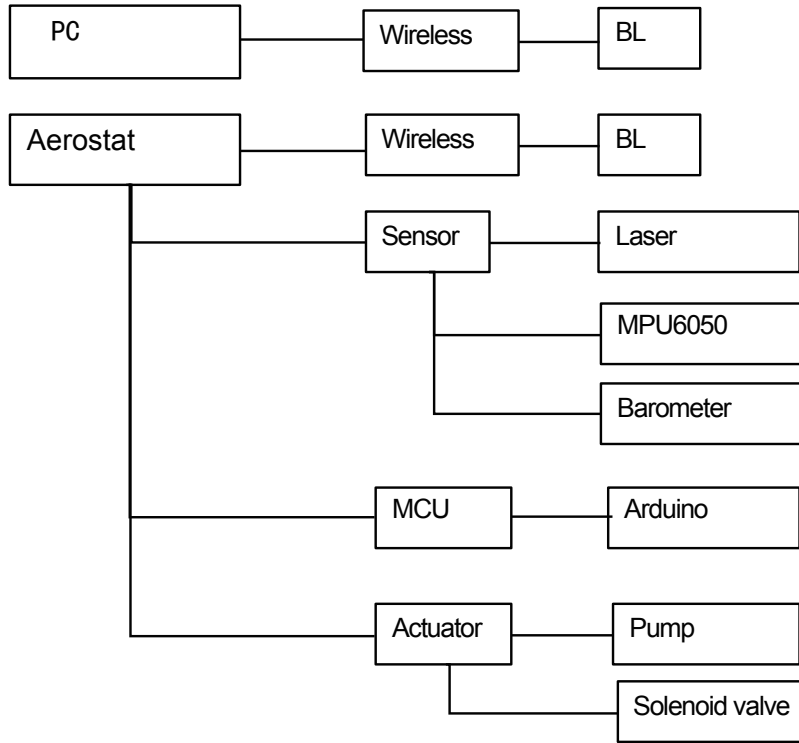

Laser rangefinder, accuracy 1mm, measurement rate 20Hz, using the diffuse reflection phase difference of the laser to calculate the distance, the ground is non-mirror.

The MPU6050 gyroscope measures acceleration and inclination, but the acceleration data is not available after the experiment.

The barometer is used to measure the air pressure in the air sac and to detect the overpressure state of the air sac.

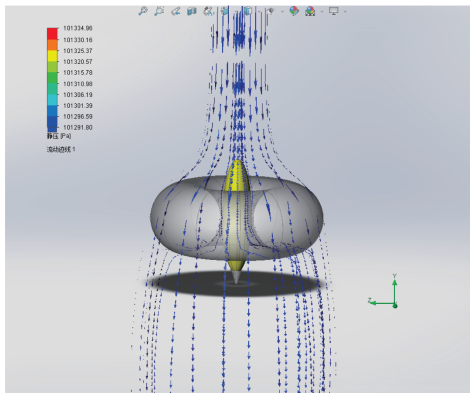
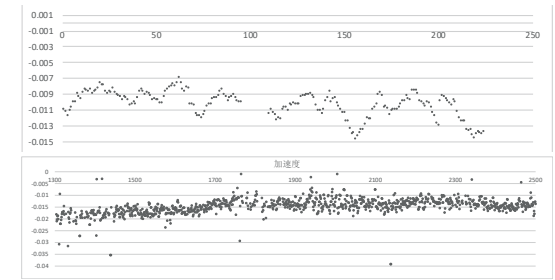
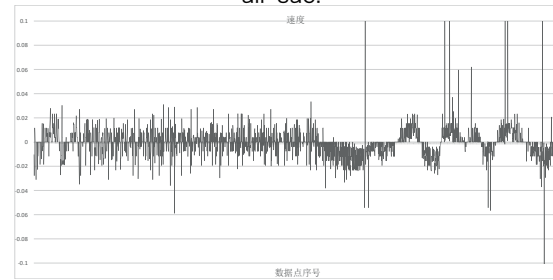
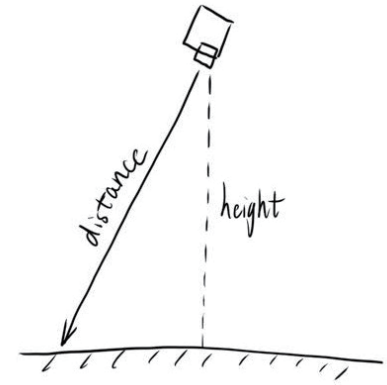

Solidworks Flow Simulation

$C_{simulation} = 0.53$

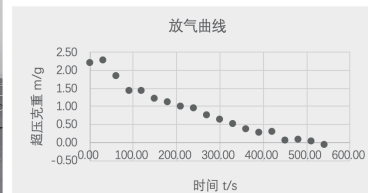
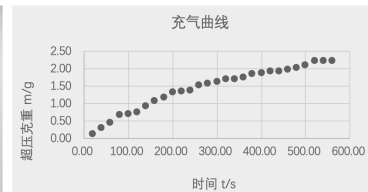

充气: $f(t) = 4.63 \times 10^{-6} x^2 - 0.006639x + 2.21 \quad 0 \leq t \leq 540$

放气: $f(t) = 0.2124x^{0.4142} - 0.6713 \quad 0 \leq t \leq 540$

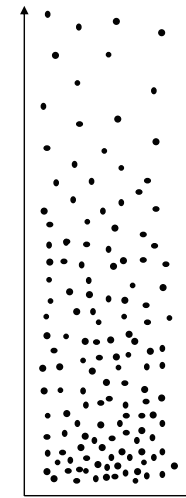

Product Design

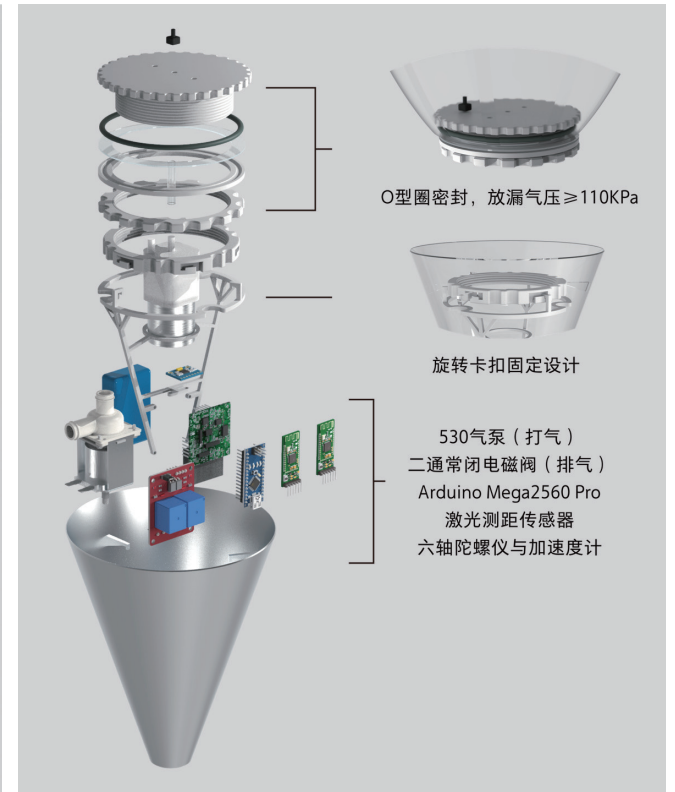
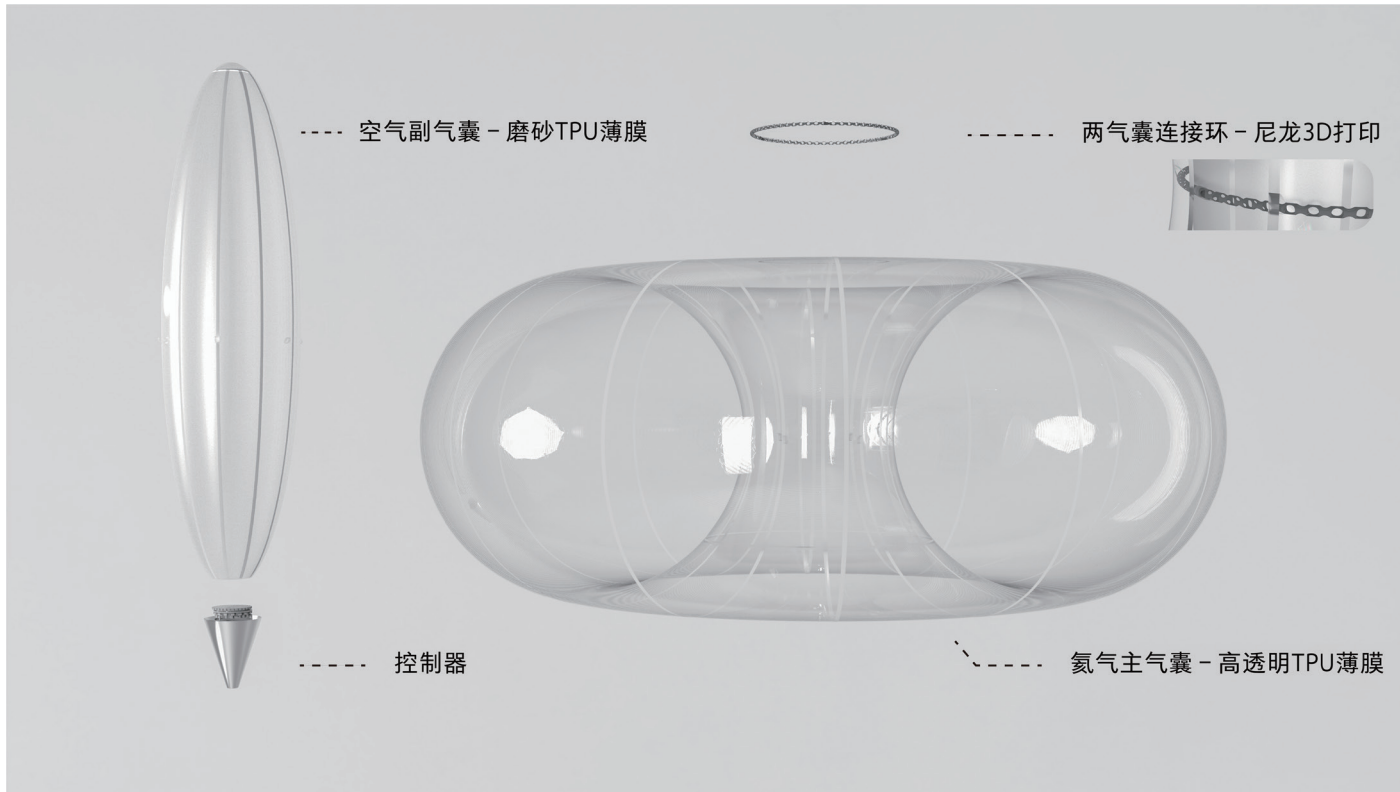

Demo

